

THE DISCHARGE OF IMPULSES IN MOTOR NERVE FIBRES. Part I. Impulses in single fibres of the phrenic nerve.

BY E. D. ADRIAN AND D. W. BRONK (*Fellow in Medicine, National Research Council, U.S.A.*).

(*From the Physiological Laboratory, Cambridge.*)

It is generally agreed that the motor nerve fibres perform their function in the body by conducting impulses of the normal type, but there is little agreement as to the way in which these impulses are discharged. According to one line of argument a powerful contraction is brought about by more or less synchronous volleys of impulses occurring at the rate of 50–80 a sec. in each motor neurone; according to another the rate of discharge is very much higher and the apparent synchronisation revealed by the electromyogram is caused by the properties of the recording instrument or of the muscle. What happens with a relatively weak contraction is too uncertain even to have become a subject for controversy. In the present investigation we have obtained direct records of the discharge in individual motor nerve fibres innervating the diaphragm. We cannot assume that our results can be applied to every kind of reflex contraction, but for this particular case they seem so definite that it is unnecessary to set out the whole of the evidence which has been brought forward by indirect methods in the past¹.

The phrenic is an ideal nerve for investigations of the activity of the motor centres, for the respiratory discharge needs no external stimulus to maintain it, its intensity can be varied by controlling the air supply to the lungs and it occurs at definite intervals separated by periods of inactivity. The electric responses in the whole nerve trunk have been recorded by Dittler and Garten⁽³⁾ with the string galvanometer, and by Gasser and Newcomer⁽⁴⁾ with the same instrument used in conjunction with a valve amplifier. Their records (made from the dog) show that in each period of inspiration the electric response takes the form of a series of oscillations at the rate of about 70 a sec. Each oscillation resembles

¹ This evidence has been summarised elsewhere by one of us⁽¹⁾ and various points have been discussed by Forbes and his co-workers⁽²⁾.

the typical mono- or diphasic wave of action potential such as would be produced by stimulating the nerve electrically. If the resemblance were complete it would follow that each oscillation is due to a synchronous volley of impulses in many fibres, but more perfect recording instruments show that the oscillations are in fact considerably longer and more complex. A lack of complete synchronisation between the different neurones would account for this, but there are other possibilities which have been put forward (Fulton⁽⁵⁾), and a study of the composite response of the entire nerve trunk is not likely to give decisive evidence however perfect our recording system may be. To be sure of what is happening in the single nerve fibre we have to devise a method which will put out of action all the other fibres in the nerve. The recording of impulses in a single fibre presents no difficulty, but the problem of isolating the fibre seemed much more formidable. Fortunately this has turned out not nearly so difficult as we had imagined.

METHOD.

Most of our experiments have been made on rabbits anaesthetised with urethane. The nerve we have used is the uppermost root of the phrenic, a slender branch arising from the third cervical nerve and running down over the scalenus anterior muscle for about 15 mm. before it is joined by the larger branch from the fourth cervical. Its motor fibres supply the anterior third of the diaphragm. Sections stained with osmic acid show that there are about 150 fibres in the nerve, all of the large medullated type with the exception of five or six very small medullated fibres. The nerve is easily dissected out in the neck and cutting it causes no obvious disturbance of respiration, since the greater part of the phrenic is left intact.

For diminishing the number of active fibres we have adopted the simple method of dissecting the nerve with fine needles under a binocular microscope. It is cut distally at its junction with the branch from the fourth cervical and laid in a pool of warm Ringer on a small platform of glass coated with black paint on its under surface. The platform is held rigidly by a rod fixed to an upright at the side of the board on which the animal rests. A Zeiss binocular dissecting microscope is focussed upon the nerve, which is illuminated from above by an electric lamp.

The first step in the dissection consists in splitting the connective tissue sheath which surrounds the nerve fibres. The sheath is pulled out on either side leaving the exposed nerve in the middle as in Fig. 1 *A*. The nerve is then split longitudinally in such a way as to leave a small strand of intact fibres in the middle (Fig. 1 *B*). The lateral bundles are cut

across by pressure with a fine hook (Fig. 1 *C*) and the central strand is then split in the same way. The object of the dissection is to leave a few

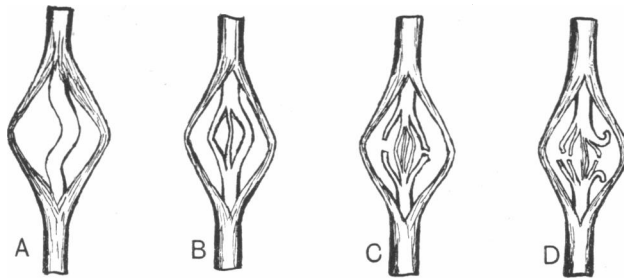

Fig. 1. Method of dissecting nerve so as to divide all but two or three fibres.

fibres in the middle of the nerve intact but separated as far as possible from one another. If this is accomplished, the remaining fibres are cautiously divided until only the smallest strand is left joining the two ends of the nerve (Fig. 1 *D*). We have rarely attempted to carry the dissection to the stage at which only one fibre is left undivided. One fibre chosen at random might turn out to be afferent and not motor, and it is much harder to isolate a single fibre than to isolate a group of three or four. The electrical records usually provide sufficient evidence of the number of motor fibres in action, and the actual number of undivided fibres can be checked by microscopical examination after the experiment is over. The number of undivided fibres has always been greater than the number of motor fibres which appear to be in action in our records.

The process of dissection and still more the subsequent manipulation of the nerve might be expected to prove rapidly fatal to the few fibres which bridge the gap, but fortunately the connective tissue sheath (which has been split but not cut transversely) acts as a most effective splint and prevents undue tension or displacement. In fact the nerve can be handled as though it were still undamaged, and the surviving fibres give a discharge which shows no signs of alteration for periods as long as two hours.

Each stage in the dissection is controlled by observing the impulse discharge in the nerve distal to the division. The distal portion is slung on two small paint brush electrodes (cf. Adrian and Zotterman⁽⁶⁾), the proximal connected to earth and the distal to the input of the three valve amplifier described elsewhere⁽⁷⁾. The amplified action currents can be photographed with the capillary electrometer, but until the final stages are reached it is usually more convenient to lead them to a telephone or

loud speaker and estimate the character of the discharge by the ear instead of the eye.

The use of the telephone for investigating nerve or muscle action currents is well known, for the telephone has much the same electrical sensitivity as the string galvanometer. We have been accustomed for some time to use a telephone connection in the output of the amplifier system before making photographic records. In the present work, however, in addition to the telephone we have found it a great convenience to have a continual sound record of the nerve discharge made by a loud speaker. This has a separate two valve transformer-coupled amplifier of its own and it is connected to the output of the main amplifier through a $\cdot 01$ mf. condenser. As the connection to the electrometer is through a 1 or 10 mf. condenser and a 120,000 ohm resistance the loud speaker connection introduces practically no distortion nor reduction in amplitude in the electrometer record. The arrangement of the connections is shown in Fig. 2. When only a few fibres are in action the electrometer

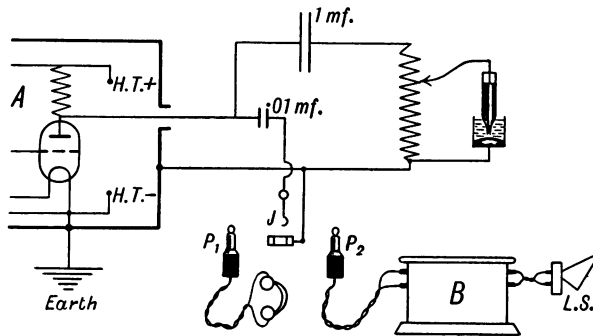

Fig. 2. Connections for telephone or loud speaker used simultaneously with capillary electrometer. The output of the main amplifier *A* (last stage only shown in figure) is connected through a $\cdot 01$ mf. condenser to the jack *J*. The plug *P*₁ leads to a telephone and *P*₂ gives an alternative connection to the loud speaker *L.S.* through the second amplifier *B*.

excursions may be too small to detect on a screen, but they produce a series of faint clicks in the loud speaker, and it is thus possible to control the dissection, to expose a plate at the moment when the discharge is at its height, etc., without the inconvenience of wearing telephones.

When photographic records are to be taken the animal is placed on an insulated platform inside an earthed metal box, to avoid a slight ripple from alternating current mains which often appears when the preparation is unshielded.

RESULTS.

(a) *The discharge of the entire nerve.*

A large number of records have been made in different animals before the division of the nerve fibres. In normal quiet breathing, which occurs at a rate of about 55 a minute in the rabbit, each discharge lasts about

$\frac{1}{2}$ sec. and consists of an irregular and rapid succession of potential changes. There is sometimes an indication of large excursions recurring at a frequency of about 20–30 a second, but it is often difficult to make out any kind of regularity. When forcible inspiratory movements are produced by clamping the air tubes to the trachea, each period of contraction may last as long as a second and the rate of respiration slows down. The character of the discharge changes and it becomes much more like the phrenic discharge in the dog as recorded by Gasser and Newcomer¹. Instead of the irregular succession of potential changes there appears a more or less orderly sequence of large waves at frequencies ranging from 50–90 a sec. The degree of regularity varies from one animal to another, but it is always more pronounced with forcible breathing. The discharges shown in Fig. 3 are fairly typical, and records from the highest root of the

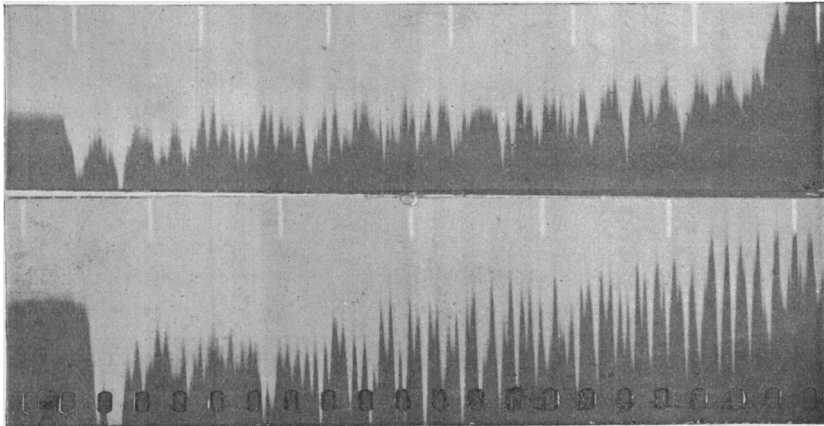

Fig. 3. Action current record of 3rd cervical root of phrenic, all nerve fibres intact. *Above*: normal breathing (discharge lasts somewhat longer than usual). *Below*: air tubes clamped. Discharge shows large waves with a greater approach to regularity. Time marker gives $\cdot 125$ sec. intervals.

phrenic in the decerebrate cat show much the same change. It may be noted here that the electromyogram of a voluntary contraction has the same tendency to develop regular waves at 50–70 a sec. (the Piper rhythm) when the contraction is forcible and prolonged.

¹ In Gasser and Newcomer's experiments the thorax was opened and the lungs were inflated artificially, though there is no reason to suppose that the respiratory discharge was more intense than it would be in normal breathing.

(b) The discharge of individual fibres.

The effect of the reduction in the number of active fibres can be seen in Fig. 4 (Exp. 14). The records are from plates, all of which were exposed

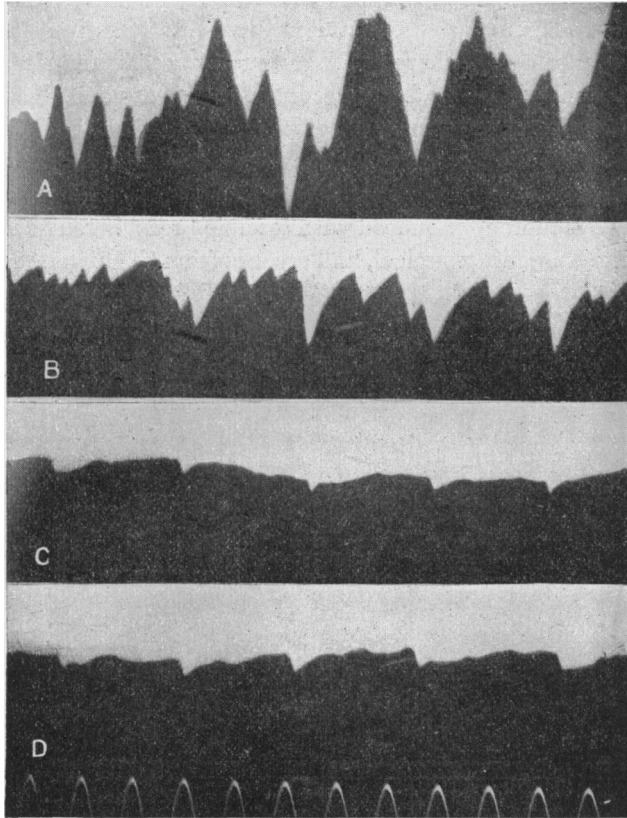

Fig. 4. Action currents at different stages of dissection. Exp. 14. Normal breathing. *A.* Nerve intact. Electrometer one-fourth maximum sensitivity. *B.* About nine-tenths of the fibres divided. Maximum sensitivity. *C.* All but three fibres divided, but probably only one in action. The impulses form a single series at a frequency of 40 a sec. *D.* Another record made some minutes later. Time marker gives $\cdot 01$ sec. intervals.

during the period of inspiration but not necessarily at the same time after the beginning of the discharge. In *A* both electrodes are on the proximal, undivided part of the nerve and the electrometer is shunted to one-fourth of its normal sensitivity. The record shows the complex structure of the large excursions in quiet breathing. In *B* about nine-tenths of the nerve

fibres have been cut, the electrometer is working at its maximum sensitivity and the individual impulses can be seen. At intervals of about $\cdot 025$ sec. several impulses coalesce into larger excursions. In *C* still more of the fibres were divided and the record shows a single series of impulses recurring at intervals of $\cdot 023$ – $\cdot 025$ sec. *D* is another record where the impulses are not spaced quite so regularly.

The nerve was examined after the experiment was over and it was found that the gap was bridged by three fibres. Two of these showed no sign of damage but the third was badly contorted. Of the two fibres which appeared to be undamaged it is unlikely that more than one is concerned in the discharges shown in Fig. 4*C* and *D*, for the impulses appear to form a more or less regular series and never follow one another at less than $\cdot 02$ sec. Records on bromide paper covering the entire period of inspiration show that almost all the impulses occur in a single series, though there is a suggestion of two impulses at a much closer interval at

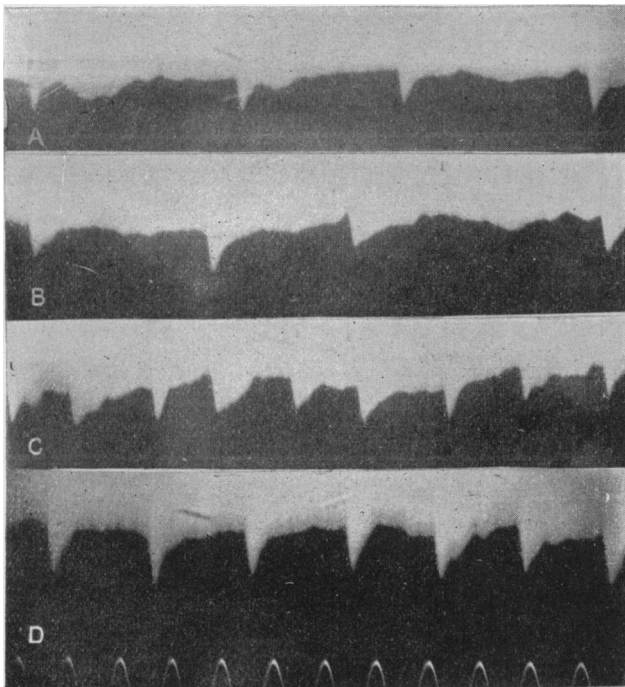

Fig. 5. Exp. 13. Final stage of dissection. *A* and *B*. Normal breathing. Frequency of impulses 27 a sec. *C* and *D*. Air tubes clamped. Frequency 68 a sec. in *C* and 55 in *D*.

the very beginning of the discharge. It is possible therefore that the second fibre transmits an occasional impulse, though it may well have been an afferent fibre from the end organs in the muscle.

The discharges in Fig. 4 were all obtained during unobstructed breathing. In this animal cutting off the air supply gave a discharge in the intact nerve which was longer but not much larger or more regular than with normal breathing and the force of the movements was not much increased. Records from the nerve below the divided area during asphyxia show some increase in the frequency of the impulses, but the change is only from an average of 37 to an average of 50 a sec.

The effect of clamping the air tubes is shown more clearly in Figs. 5, 6 and 7 (Exps. 13 and 19). In both of these preparations the gap in the

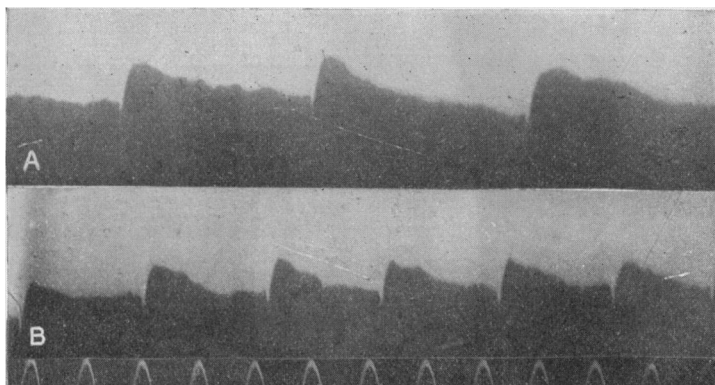

Fig. 6.

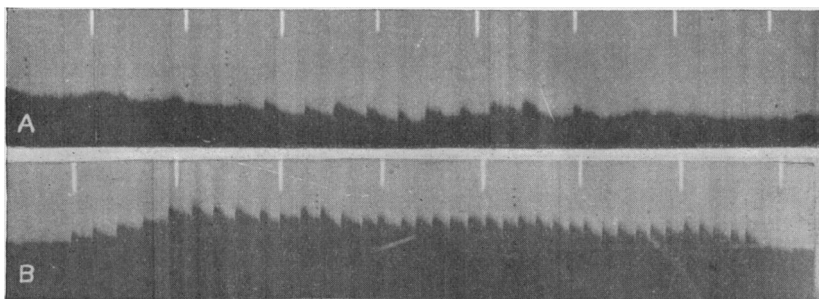

Fig. 7.

Fig. 6. Exp. 19. Final stage. *A*. Normal breathing. Frequency of impulses 28 a sec. *B*. Air tubes clamped. Frequency 50 a sec.

Fig. 7. Exp. 19. Final stage. Discharge throughout the period of inspiration. *A*. Normal breathing. *B*. Air tubes clamped. Time marker gives 0.125 sec. intervals.

nerve was bridged by four or five undivided fibres, but the discharge has the same character as in Exp. 14, *i.e.* the impulses appear to form a single series. With normal breathing the frequency of impulse discharge is slower than in Exp. 14 (about 27 a sec.) and the increase on asphyxia is greater, the frequency rising to 68 a sec. in Fig. 5 C. Fig. 7 gives the discharge during the entire period of inspiration in Exp. 19 and shows the increased duration in asphyxia as well as the increased frequency.

The records in Figs. 4-7 are typical of a large number obtained from these three experiments and from two others where the dissection was

TABLE I.

Frequency of discharge in preparations giving a single series of impulses. Data obtained from continuous records of several periods of inspiration.

	Normal breathing		Air tubes clamped	
	Maximum frequency per sec.	Average frequency per sec.	Maximum frequency per sec.	Average frequency per sec.
Exp. 12	18	15	82	40
	23	19	60	38
	19	15	68	50
Exp. 13 (a)	26	23	72	43
	29	21	80	56
	28	25	80	60
(b)	24	21	86	51
	25	21	104	72
	26	23	112	78
Exp. 14	48	35	56	46
	48	38	60	50
	48	31	50	51
Exp. 17	24	22	42	27
	24	20	42	30
Exp. 18	24	18	64	36
	26	20	44	35
Exp. 19	27	25	50	37
	28	26	50	43
	28	25	60	47

TABLE II.

Duration of interval between successive impulses in "single fibre discharges," throughout the period of inspiration.

Exp. 13.

Normal breathing. Intervals (secs.): .049, .045, .038, .032, .028, .029, .028, .027, .028, .030, .027, .028, .073.

Air tubes clamped: .072, .056, .040, .032, .028, .028, .025, .021, .023, .023, .017, .020, .021, .021, .016, .022, .016, .017, .020, .022, .016, .017, .016, .024, .022, .019, .014, .027, .024, .112.

Exp. 19.

Normal breathing: .056, .054, .040, .044, .038, .034, .040, .039, .052.

Air tubes clamped: .032, .032, .036, .033, .032, .030, .032, .025, .025, .025, .028, .030, .024, .028, .024, .025, .024, .024, .025, .024, .025, .025, .024, .023, .023, .026, .024.

successfully carried to the stage at which a single series of impulses appeared. The data as to frequency and regularity of the impulses are given in Tables I and II which are constructed from continuous records of the type shown in Fig. 7. It will be seen that all five experiments agree very closely with one another and this is perhaps the best proof that they show the normal discharge of a single nerve fibre. In every case we are dealing with a nerve containing several undivided fibres (the actual number varying from three to six or more), but a further reduction in the number of fibres has always left us with one or two apparently intact but with no impulse discharge of any kind. In fact we have never found any intermediate stage between the complete absence of a discharge and one of the type shown in Figs. 4-7. For this reason it is extremely unlikely that such discharges are produced by two or more fibres acting in rotation, and we may accept them as due to a single fibre. As examples of the type of discharge due to several fibres we may take Fig. 8 (Exps. 12 and 22).

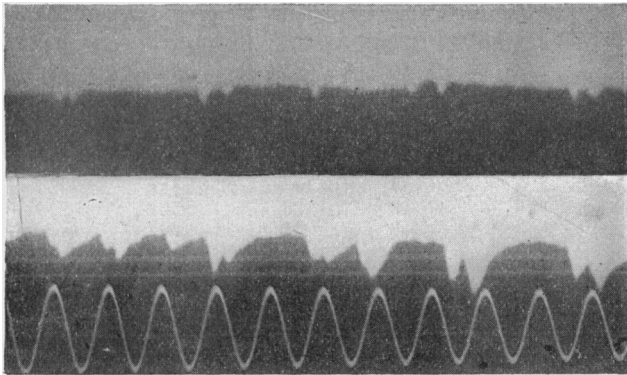

Fig. 8. Grouping of impulses in preparations with several intact fibres. *Above: Exp. 16. Two fibres in action. Below: Exp. 32. Four fibres in action.*

In both of these there were five or more undivided fibres and the impulses are obviously grouped.

The uniformity in the "single fibre" records makes it unlikely that they are the product of nerve fibres which have been so damaged as to affect their power of conduction, and this is supported by the fact that the character of the discharge does not change appreciably in the course of an hour or more.

There are, however, two points in which there is a departure from normal conditions. These are, first, that the animal is under an anæsthetic and, second, that the afferent fibres in the nerve have all been cut. The

effect of an anæsthetic is almost certainly negligible, for it makes no difference to the rate or character of the respiration and the intact nerve discharge shows the same features in the decerebrate cat when the effect of the anæsthetic has worn off. The effect of cutting the afferent fibres will be dealt with later. Admitting, however, that the conditions are to this extent abnormal we may proceed to examine the single fibre discharge in more detail.

Duration and magnitude of electric responses. An analysis of the responses made with Lucas's instrument from the electrometer records shows the typical form of a wave of action potential in a single fibre, but our records do not give much information as to the precise duration of the response, since we have no exact information of the temperature of the nerve¹. As in the case of sensory fibres the magnitude of the responses appears to depend entirely on the local condition of the nerve. They may vary from one record to another owing to the variable amount of fluid on the nerve and to the readjustment of the electrodes, but they show no sign of increasing in size when the respiration is more forcible. This may

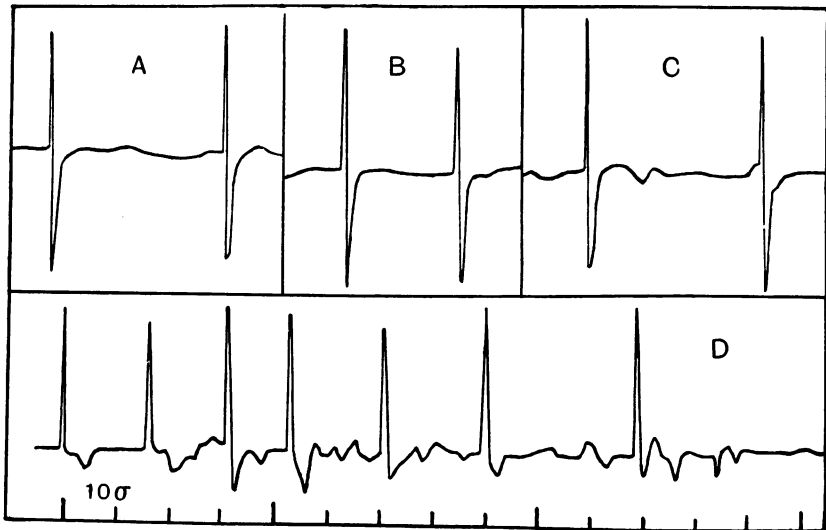

Fig. 9. Analysis of electrometer records showing constant size of action currents. *A, B and C.* Exp. 19. Nerve under constant conditions throughout. *A.* Normal breathing. *B.* A few minutes later. Air tubes clamped. Forcible respiratory movements. *C.* A few minutes later. Normal breathing. *D.* Exp. 13. Record at end of forcible inspiration with air tubes clamped.

¹ The nerve was irrigated with warm Ringer, but the air in the animal box was below 35° C., and the temperature of the nerve would fall off between successive irrigations.

be seen from Fig. 9 which gives the corrected curves from three records made in the space of a few minutes without touching the nerve. In *A* and *C* the animal is breathing normally and in *B* the air tubes have been clamped. Fig. 9 *D* is another example of the constant size of the responses. The record was taken at the end of a powerful inspiration with the air tubes clamped and it will be seen that although the frequency declines rapidly, there is no change in the size of the individual responses beyond the range of experimental error.

Frequency of impulses. Tables I and II show that the frequency in the discharge of a single fibre varies from about 20–30 a sec. during normal breathing to 50–80 a sec. in asphyxia. The impulses are spaced more or less evenly: the amount of departure from complete regularity varies from one preparation to another, but it is much the same in any one preparation whatever the frequency of the discharge. At the beginning and end of inspiration the intervals between the impulses are longer, but there is no distinct pause in the discharge except that between each period of inspiration. During this pause, which lasts about $\frac{1}{2}$ sec., there is no sign of nervous activity. The highest frequency recorded in a single fibre discharge is 112 a sec. (Exp. 13), but as a rule the frequency does not rise above 80 a sec. although the asphyxia has been pushed to the point at which convulsive movements begin.

Grading of muscular contraction. The character of the single fibre discharge during a powerful inspiration was not at all unexpected. The most reasonable interpretation of Gasser and Newcomer's experiments is that each nerve fibre transmits a series of impulses at about 70 a second, and the work of Bass and Trendelenburg⁽⁸⁾, Cooper and Adrian⁽⁹⁾ and others has made it most likely that the frequency of discharge in the nerve fibre was no higher than the frequency of the large waves in the electromyogram. We were less prepared to find such low frequencies as 20 a sec. in a submaximal contraction, though there was a certain amount of indirect evidence to suggest it¹. It is obvious, however, that the variations in the frequency of the discharge between the limits of 20 and 80 a sec. are excellently adapted for producing contractions of graded intensity without bringing fresh muscle fibres into play. A mammalian muscle stimulated 20 times a second gives an incomplete tetanus, and the tension increases with the frequency of stimulation until the individual twitches have become completely fused. If all the muscle fibres are activated simultaneously, as they must be with stimulation of the motor

¹ Cf. the work of Wachholder⁽¹³⁾ and of Richter⁽¹⁴⁾ on the voluntary electromyogram.

nerve, the contraction will proceed in a series of jerks when the frequency of stimulation is below the fusion point; but if the different groups of muscle fibres are not synchronised the whole muscle will contract more or less smoothly. The irregular character of the discharge from the whole nerve in quiet respiration shows that there is, in fact, no well-marked synchronisation at the lower frequencies, and the diaphragm will therefore contract smoothly although the tension in each muscle fibre would show a series of peaks and depressions.

As the frequency needed for a smooth maximal contraction varies from one muscle to another, we have made a rough determination of the curve relating force of contraction to frequency of stimulation for the rabbit's diaphragm. In a rabbit anaesthetised with urethane and chloroform both carotids were tied and the cerebral circulation was occluded by a ligature tied tightly round the neck below the transverse process of the atlas. The respiration was maintained artificially and discontinued for short periods when the phrenic was stimulated. The 4th cervical root of the nerve was used instead of the 3rd as it produces a more powerful contraction. Stimulation was by a series of break shocks from a coreless induction coil connected with a rotating interrupter, the speed of which could be read directly by a magnetic speedometer. The force of contraction was recorded by connecting the air tube from the trachea to a water manometer, the reading being taken after 2-3 sec. stimulation when the pressure had reached a steady value.

A curve made from a typical set of readings is shown in Fig. 10. The

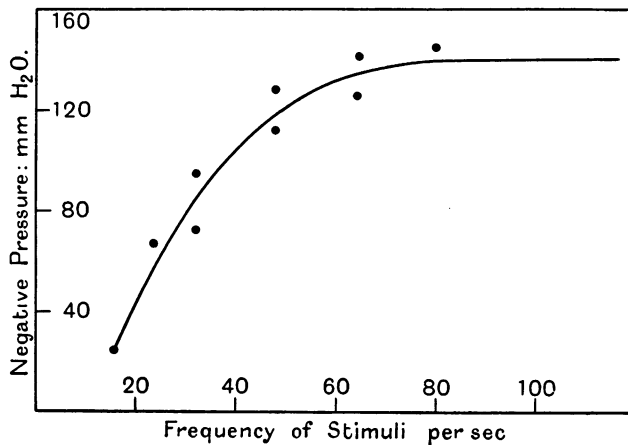

Fig. 10. Exp. 20. Negative pressure in thorax produced by stimulating 4th cervical root of phrenic at different pressures. Frequencies varied in random order.

method of recording may give an exaggerated idea of the actual change in average muscular tension at the different frequencies, but it shows well enough that the suction caused by the diaphragm is approximately doubled when the stimulation frequency rises from 25 to 60 a sec. and that there is little further change when the rate exceeds 60 a sec. Thus the frequencies which we find in the single nerve fibre cover just the range which will give the maximum variation in the force of contraction.

It has been generally assumed that in a submaximal contraction of reflex origin only a portion of the muscle is in action, more and more motor neurones taking part as the contraction increases in force. It is, therefore, of interest to enquire how far this method of gradation is made use of in the rabbit's diaphragm to supplement that provided by the variation in the frequency of the discharge. The answer must be that as far as concerns that part of the muscle which is supplied by the 3rd cervical root of the phrenic there is no marked increase in the number of neurones in action when the contraction becomes more forcible, the gradation being due mainly to the increased number of impulses which reach the muscle from each nerve fibre. If many of the nerve fibres are only brought into play with forcible breathing we should expect to find some preparations in which the few remaining nerve fibres transmit impulses only when the air supply is cut off. Actually in all the experiments where we have obtained single fibre discharges these have occurred in quiet breathing as well as in asphyxia. In some of the experiments where a greater number of fibres were intact the increased discharge during asphyxia seems large enough to indicate the accession of fresh nerve fibres, but it is difficult to be sure of this. No doubt an examination of the other nerve roots of the phrenic might show that some of the fibres are only active during a powerful contraction, for the force of contraction must increase many times when the air tubes are clamped, whereas an increase in the discharge frequency from 20 to 60 a sec. would not be likely to account for much more than a two-fold increase.

Evidence pointing to the accession of fresh nerve fibres in forcible breathing has been obtained in an experiment in which a decerebrate cat was used instead of a rabbit. In this preparation the 4th cervical root (the highest in the cat) was dissected. When the final stage in the division was reached, the distal part of the nerve remained completely quiet during normal breathing, but a distinct impulse discharge could be heard in the loud speaker when the air supply was cut off. After a few minutes an impulse discharge appeared during normal breathing as well, indicating that some fibres had been temporarily thrown out of action by pressure

during the dissection and had now recovered their power of conduction. For this reason the experiment is scarcely conclusive, for the appearance of impulses only in forcible breathing might have been due to summation occurring in a partially damaged fibre.

In the experiments on the rabbit we have looked for evidence of the accession of fresh fibres as the contraction develops by comparing the duration of the single fibre discharge with that of the whole nerve. If more and more fibres come into play during the course of inspiration, the discharge of the whole nerve would usually outlast that of the single fibre, for it is unlikely that the fibre we isolate would always turn out to be one which comes into action at the beginning of inspiration. In general, however, we have found no clear evidence of the single fibre discharge being much shorter than that of the whole nerve. The average duration of both is about $\frac{1}{2}$ sec. in normal breathing, and there is no indication of a constant difference in length in any one experiment. It must be admitted that a difference as large as 20 p.c. might pass unnoticed, for the duration of the discharge varies somewhat in the course of the experiment.

Synchronous activity of motor neurones. When the impulses in each fibre recur at a frequency as low as 25 a sec. the contraction of the diaphragm would proceed in a series of jerks if there were an exact synchronisation of the discharge in the different nerve fibres. Records such as those in Figs. 4 and 8 show that there is some tendency for the impulses in different fibres to occur at the same moment but this is not great enough to prevent an almost constant succession of impulses from reaching the muscle. On the other hand, when the frequency in each fibre rises to 60 a sec. a smooth contraction will result whether the different neurones are discharging independently or by volleys, and it is interesting to find that the greatest degree of synchronisation does in fact occur in these rapid discharges where it will have the least effect on the smoothness of the contraction.

The synchronisation at high frequencies can be seen from a comparison of the single fibre discharge with that of the whole nerve. When the single fibre gives a frequency of 50–80 a sec. the discharge of the entire nerve becomes of the type in which there is a more or less regular series of large waves at 50–80 a sec. An example of this is shown in Fig. 11, *A* and *B*, and there can be little doubt that the discharge of the whole nerve is built up of more or less synchronous volleys.

The degree of regularity in the size and frequency of the waves in the whole nerve discharge, and therefore the degree of synchronisation, varies

from one preparation to another. Fig. 11 *C* is an example of an extremely regular discharge from an entire nerve (Exp. 7). Below it (*D*) is the dis-

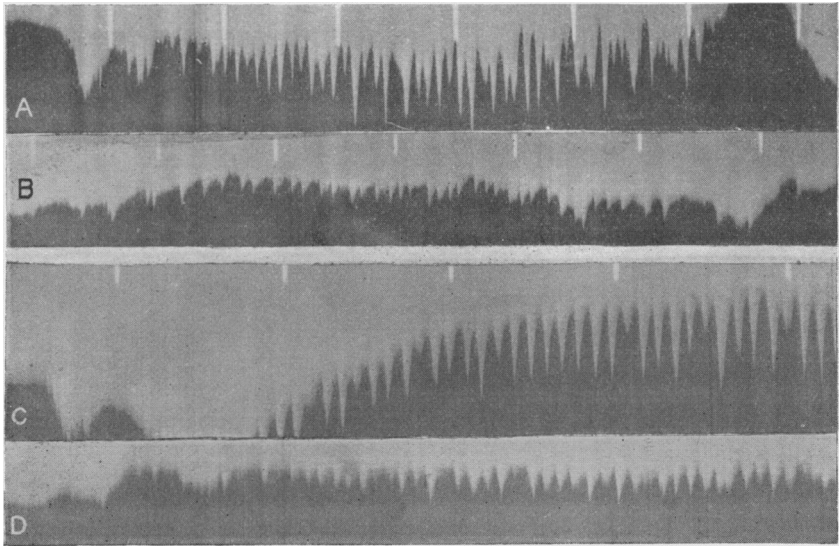

Fig. 11. Comparison of discharge of intact nerve with that of a few fibres. Air tubes clamped to produce regular rhythm. *A* and *B*. Exp. 13. *A*. Electrodes close together above the dissected area. *B*. Electrodes below the dissected area. The record shows individual impulses, most of which appear to form a single series. *C* and *D*. Exp. 7. *C*. Before dissection. Electrometer one-sixth maximum sensitivity. *D*. After dissection. Several fibres in action. Maximum sensitivity. Time marker gives $\cdot 125$ sec. intervals.

charge of two or three fibres which were left intact, the sensitivity of the recording system being six times as great as in *C*. Even here the synchronisation is not absolute, for it is occasionally possible to detect more than one impulse in the waves of the lower record. There is no doubt that the chief condition for the synchronous activity of the neurones is that the discharge should be near its maximum intensity, but we have not been able to make out what other conditions may favour or hinder its appearance.

Influence of afferent fibres. A factor which might be likely to affect both the synchronisation and the frequency of the discharge in our records is the absence of the proprioceptor impulses which normally pass up the nerve. Dusser de Barenne⁽¹⁰⁾ and others have shown that the frequency of the large waves in the electromyogram may be reduced by

30 p.c. or more when the muscle is deafferented and the regularity may become greater when the frequency is reduced by painting the dorsal part of the cord with novocaine. It was possible therefore that the discharges we have obtained are of lower frequency and greater regularity than they would have been had the afferent fibres been undivided.

Though we cannot deny the importance of the afferent fibres we do not think that the general character of the discharges has been much affected by their destruction. The greater part of the proprioceptor supply from the diaphragm has been left intact, for the 3rd cervical root is only a small part of the phrenic, though it must be admitted that the afferent fibres which have been divided are those which are most intimately connected with the motor fibres we have studied. But we can form some estimate of the extent to which the discharge is affected by comparing it with that occurring in the nerve before it has been severed from its connection with the diaphragm. The records obtained by leading off from a nerve trunk which preserves both central and distal connections are complicated by the fact that they will contain afferent as well as efferent impulses and that they may be affected by changes of potential occurring in other parts of the body. The chief disturbance is that due to the heart, but fortunately the electrocardiogram is easily recognisable and it can be reduced in magnitude by adjusting the position of the electrodes on the nerve. We have recorded the discharge of the nerve in continuity in three experiments and compared it with that from the same nerve after cutting distally or from the cut nerve on the opposite side of the body. In no case was there any marked change in the frequency or regularity of the record. With quiet breathing the discharge has the usual irregular character with occasional large waves, and with asphyxia there was the usual increase in the number of the large waves, the dominant frequency reaching the typical value of 70–80 a sec. In none of these experiments with the nerve cut or uncut was the asphyxial discharge as regular as that shown in Fig. 11 *C*, and it is difficult to make exact comparisons in records which fall short of complete regularity; but the well-marked change in the character of the discharge as between quiet breathing and asphyxia is fairly clear evidence that the change from asynchronous to synchronous activity takes place whether the afferent fibres are intact or not.

It may be that the frequency in each nerve fibre is slightly higher when the afferent fibres are intact, but our records give no indication of this for the large waves occur at much the same rates with the nerve cut or uncut.

In this connection the experiments of Gasser and Newcomer may be recalled, for they too recorded the discharge in the nerve in continuity and found it to have the same dominant frequency as in a nerve cut distally. Moreover, they made simultaneous records from the right phrenic cut distally and the left half of the diaphragm with intact nerve supply and were able to detect corresponding waves in the two records (11). Here therefore the discharge of the right phrenic with its proprioceptor fibres cut through is synchronised with that of the left phrenic which is still connected with the diaphragm.

DISCUSSION.

It is unlikely that the innervation of the diaphragm differs much from that of an ordinary skeletal muscle, and we may expect to find that the discharges of other motor neurones will have the same general character as those of the phrenic. But there is no reason why the same method of dissection should not be applied to the nerves supplying the skeletal muscles, and until we have done this it would be premature to discuss our results as though they had been found in all kinds of reflex discharge. To mention only one possibility, it may be that a group of motor neurones which are activated by a centre in the brain stem will give a different type of discharge from those activated in a short spinal reflex. At the same time it will be surprising if such a finding as the gradation of contraction by the change in frequency of the discharge does not turn out to be generally applicable, for it removes certain difficulties which arise from the view that gradation is mainly due to a change in the number of fibres in action. This is the most interesting, because the least expected, of our results. For the present, however, we may treat the phrenic discharge as a good example of the general principles which seem to govern the activity of the neurone, without implying that other motor discharges may not differ considerably in detail.

Previous work has shown that in the sensory nerve fibres the impulses produced by stimulation of the end organ are of fixed size and that they recur at more or less regular intervals with a frequency which is determined by the intensity of the stimulus, but is never high enough to prevent the fibre from recovering after the passage of each impulse. The present investigation shows that the motor fibres of the phrenic transmit discharges which are almost an exact counterpart of those in the sensory fibres. The impulses (or rather their action potentials) obey the same all-or-nothing principle; their frequency varies with the intensity of the central excitation, and varies over much the same range as in the sensory

fibre. The upper limit of the motor discharge in the phrenic is somewhat lower than that from a sensory end organ (which may reach as much as 150 a sec.), but an increase to higher rates would be of no obvious value in the motor fibre, for it would cause no further increase in the force of contraction. If we compare the sensory discharge in a small nerve with the motor discharge in a few fibres of the phrenic the chief difference is that each sensory fibre acts independently so that the impulses in the different fibres are distributed at random, whereas in the motor fibres there is often a considerable degree of synchronisation so that the impulses occur in groups (cf. Fig. 8). It may turn out that a synchronous discharge of this kind is only met with when we have a spinal centre acting under the control of the brain stem or cerebrum. If the discharge from the higher centre is conveyed by a few nerve fibres to a large number of motor neurones, a group of adjacent neurones may discharge in unison because the whole group is innervated by a single fibre from above. But the fact that the entire phrenic (in Gasser and Newcomer's experiments) gives a discharge in volleys shows that somewhere in the central nervous system (either in the respiratory centre or in the phrenic nuclei in the cord) the neurones must be linked together to work in unison. It was to obtain some evidence on this point that our research was originally planned. In a recent paper on the optic nerve Adrian and Rachel Matthews⁽¹¹⁾ described a rhythmic type of discharge occurring when the entire retina is evenly illuminated, and concluded that it was due to a synchronous activity of the different ganglion cells. It was suggested that the development of a synchronous beat might be a natural reaction in any large group of neurones connected with one another and uniformly excited, and the existence of a dominant rhythm in the electromyogram of a powerful contraction was mentioned in support of this. The present results bring the motor discharge in the phrenic into line with the discharge of the optic nerve in so far as they show the synchronous working of the motor neurones in forcible inspiration.

In both cases a feeble or restricted excitation gives an asynchronous discharge, but the explanation advanced for the retina (lack of uniformity in the excitation of the different ganglion cells) will scarcely apply to the phrenic where there is no evidence that a feeble excitation is not uniformly distributed. If it were not uniform we should expect to find much greater variation in the single fibre frequencies in quiet breathing. For this reason the precise mechanism which determines the synchronous discharge must be left until more evidence is available.

We need not discuss the whole question of the voluntary and reflex

electromyogram and the relation it bears to the nerve discharge until we have examined other nerves than the phrenic. In this particular case Gasser and Newcomer's experiments had already shown that the electromyogram is a fairly accurate copy of the electroneurogram, and that the frequency of the large waves gives the frequency of the volleys which are discharged by the motor nerve cells. In discussing the reflex electromyogram in the frog Cooper and Adrian concluded that the small waves in the record were produced by the activity of a few units acting out of phase with the majority, as Piper had originally suggested. This conception was embodied in a diagram (Fig. 7 of their paper⁽¹²⁾). For the action current record of the phrenic this diagram could be applied without any modification, and indeed it bears a striking resemblance to the actual records in Fig. 4 of the present paper.

SUMMARY.

Records have been made of the electric responses in single motor fibres of the phrenic nerve of the rabbit during the normal respiratory discharge. The highest root of the phrenic was almost completely divided with fine needles so that only three or four fibres remained intact and the electric responses in the nerve distal to the division were examined with the capillary electrometer and valve amplifier. In five experiments the dissection of the nerve was carried to a stage at which a single series of impulses appeared in the records. From these and others where more fibres were in action we draw the following conclusions:

(1) With normal breathing the impulses in each nerve fibre recur at a frequency of about 20–30 a sec. throughout the period of inspiration.

(2) When forcible inspirations are produced by clamping the air tubes to the trachea the frequency of the impulses rises to 50–80 a second, the highest recorded frequency being 112.

(3) The size of the action currents remains unaltered when the force of inspiration is increased or reduced, the only change being in the frequency of the discharge.

(4) With low frequencies of discharge, as in normal breathing, the different nerve fibres do not work in unison, though there is some tendency towards a grouping of the discharge. With the high frequencies (in forcible breathing) there is a much greater synchronisation, and the discharge consists of successive volleys from the majority of the nerve cells.

(5) The grading of the contraction in the diaphragm appears to depend mainly on the changes in the frequency of the impulse discharge in each nerve fibre. At low frequencies each group of muscle fibres will

give an incomplete tetanus, but as the groups are not all working in unison, the whole muscle will contract smoothly. When the phrenic is stimulated artificially by a series of shocks an increase in frequency from 25 to 60 a sec. doubles the suction produced by the diaphragm.

(6) It is possible that fresh nerve fibres are brought into play when the force of inspiration is increased, but this method of gradation does not seem to have much importance in comparison with that due to the change in discharge frequency.

(7) The electric response of the entire nerve consists of a succession of large waves which vary in size and regularity according to the force of the respiratory movement, and are due to a more or less synchronous discharge in a number of fibres; and of small waves, more prominent in quiet breathing and due to fibres working out of phase with the rest but at much the same frequency.

(8) Though some of the afferent fibres from the diaphragm were cut through in our experiments, it does not appear that the general character of the impulse discharge has been much affected by their loss, for the discharge of the whole nerve is of the same type whether the distal connections are intact or not.

The expenses of this work have been defrayed by a grant to one of us (E. D. A.) from the Government Grants Committee of the Royal Society.

REFERENCES.

1. Adrian. *The Lancet*, pp. 1229 and 1282. 1925.
2. Forbes and Rappleye. *Amer. Journ. of Physiol.* 42. p. 228. 1917.
Forbes and Olmsted. *Ibid.* 73. p. 17. 1925.
Forbes and Barbeau. *Ibid.* 80. p. 705. 1927.
3. Dittler and Garten. *Ztsch. f. Biol.* 53. p. 420. 1912.
4. Gasser and Newcomer. *Amer. Journ. of Physiol.* 62. p. 496. 1922.
5. Fulton. *Muscular Contraction and the Reflex Control of Movement.* Baltimore, p. 477. 1926.
6. Adrian and Zotterman. *This Journ.* 61. p. 467. 1926.
7. Adrian. *Ibid.* 61. p. 49. 1926.
8. Bass and Trendelenburg. *Ztsch. f. Biol.* 74. p. 121. 1921.
9. Cooper and Adrian. *This Journ.* 58. p. 209. 1924; 59. p. 61. 1924.
10. Dusser de Barenne. *Skand. Arch. f. Physiol.* 43. p. 107. 1923.
Dusser de Barenne and Brevée. *This Journ.* 61. p. 81. 1926.
11. Adrian and Rachel Matthews. *This Journ.* 65. p. 273. 1928.
12. Cooper and Adrian. *This Journ.* 58. p. 223. 1924.
13. Wachholder. *Pfüger's Arch.* 199. p. 594. 1923.
14. Richter. *Quart. Journ. Exp. Physiol.* 18. p. 55. 1927.